

## TQ4200 INFRA-RED REFRIGERANT GAS DETECTION SYSTEM

### FEATURES

- Cutting costs through ultra low level detection
- ECA approved, Automated Refrigerant Leak Detection System
- F-gas compliant
- No recalibration required in service
- Highly stable infra-red gas analyser
- Self-zeroing and failsafe
- Highly specific to target gas
- Multi-point sampling capability for up to 24 points
- Automatic pressure & temperature compensation
- MODBUS enabled for remote monitoring of multiple sites
- Can be integrated into third party data monitoring systems

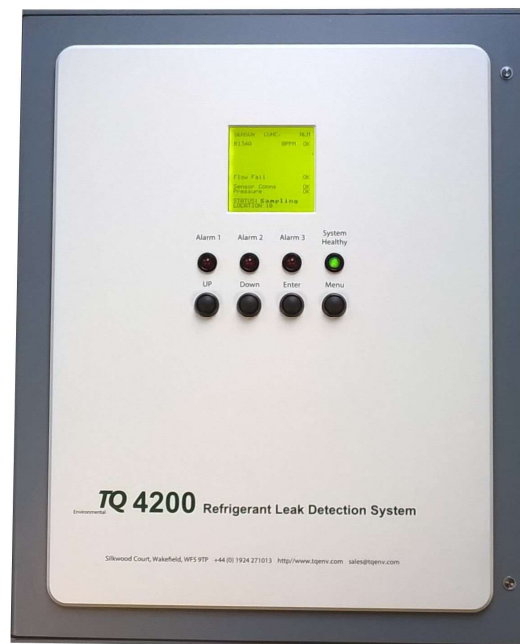

The **TQ4200** is a compact, low cost solution to multipoint refrigerant gas leak detection. With optional expansion Relay card for individual channel alarms or zone control

The system is available with a range of advanced ultra-stable infra-red gas analysers, which require NO CALIBRATION in service.

Pre-programmed with several refrigerant gas types that can easily be changed in the field.

With proven reliability and minimal maintenance the **TQ4200** is designed for both industrial and commercial use e.g. Supermarkets, IT server farms, battery back-up rooms, food processing, storage & refrigeration, air conditioning and industrial cooling facilities.

The **TQ4200** Provides F-gas solutions for larger installations and exceptional leak detection for all applications.

## APPLICATIONS

- Retail Refrigeration
- Refrigerant machinery areas
- Air conditioning systems
- Chilled water plants
- Provision stores
- IT Server Farms

The **TQ4200** system has been independently tested for inclusion in the ECA scheme, as an Automated Refrigerant Leak Detection System. Mandatory under the F-gas regulations for any refrigeration plant containing 300kg of refrigerant.

The System has a modulated broadband infra-red source to enable the detection of CFC's, HCFC's and their replacement, HFC's allowing the 4200 to accurately monitor different gas types simultaneously from a single detection panel.

Gases detected can include:- **R22, R134A, R404A, R407C, R422D, R507 and R32** with many more available upon request; providing an ideal solution when upgrading from **R22** applications.

TQ Environmental Limited, operate a policy of continual product development which means the specification is subject to change without prior notice. For full assistance with your application contact TQ Environmental.



Cert No. LRQ 0958602

TQ4200-D7-0922

The **TQ4200** samples from up to 24 points and analyses the gas sequentially from each point. Each gas sample is conditioned by passing it over particulate filters and water catch pots, to ensure that the reliability of the infra-red analyser is not compromised. Accurate multiple calibration allows sampling from independent refrigeration plants containing different refrigerant gases.

The system requires a universal 100-250 Vac power supply rated at 5 amps. Connection of the sample lines completes the self-contained operation.

SPECIFICATION	
Dimensions	8 & 16 Point: w:370 h:470 d:200 mm
Enclosure	RFI coated ABS, 12kg approx.
Tubing Connection	6mm as standard
Sample Gas Flow	0-8 litres/minute
Electrical Supply	Universal 100-250 Vac
Detection Technique	Non-Dispersive Infra-red
Gases Measured	HFC's, CFC's and HCFC's
Measurement Ranges	Typical range 0-2000 ppm
Accuracy	Minimum detection level 10 ppm Minimum Alarm point 20 ppm
Response Times	T90 <7s
Display	128*128 matrix, back lit LCD
Controls	Programmable zone ID, Red/Green LED's, front panel push buttons
Alarm Signals	4 x SPCO Volt free alarm and fault relays. Expandable with 16 or 24 relay output cards.
Output Signals	MODBUS RS485 serial communications
Temperature	-10 <sup>0</sup> C to +45 <sup>0</sup> C
Humidity	0-95%RH (Non-condensing)
Pressure/Temp Compensation	Internal automatic

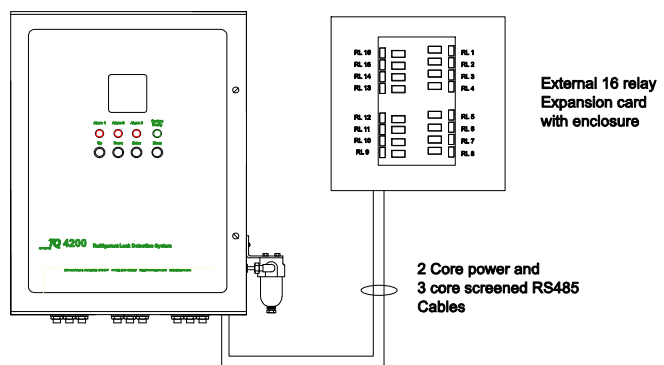

PARTS LIST	
8 Channel, Bottom Entry	370-502
16 Channel, Bottom Entry	370-500
24 Channel, Bottom Entry	370-503
16 Relay Expansion Box	370-568
24 Relay Expansion Box	370-569
Ethernet Gateway Module	720-039
6mm OD Sample Tubing	100-053
End of Line Filter	420-030